

Investigating the Use of Spliced Swimmer Bars as Shear Reinforcement in Reinforced Concrete Beams

¹Moayyad M. Al-Nasra, ²Naiem M. Asha

¹Department of Civil Engineering, Applied Science University Amman, Jordan

²Department of Civil Engineering, University of Jordan, Amman, Jordan

Abstract: - Due to the unsafe mode of shear failure in reinforced concrete beams, designers may find themselves reluctant to use higher factor of safety. Shear failure in reinforced concrete beams is one of the most undesirable modes of failure due to its rapid progression. This sudden type of failure made it necessary to explore more effective ways to design these beams for shear. The cost and safety of shear reinforcement in reinforced concrete beams led to the study of other alternatives. In this study three different shear reinforcements are used to study the effect of each type of shear reinforcement on the shear performance of reinforced concrete beams. These beams were prepared, each with different type of shear reinforcements. The first beam is considered as the control sample which used standard stirrups, the second beam used welded swimmer bars, and the third beam used spliced swimmer bars. Beam shear strength as well as beam deflection are the main two parameters considered in this study. Swimmer bar system is a new type of shear reinforcement. It is a small inclined bars, with its both ends bent horizontally for a short distance and welded, bolted, or spliced to both top and bottom flexural steel reinforcement. Welding swimmer bars to longitudinal flexural steel reinforcement in reinforced concrete beams is considered undesirable in civil engineering practice for many reasons including quality control of the weld, safety, and long term effect. Splicing swimmer bars with the longitudinal flexural steel bars is a solution to the welding problem. Special new shape of swimmer bars is used for this purpose. Regardless of the number of swimmer bars used in each inclined plane, the swimmer bars form plane-crack interceptor system instead of bar-crack interceptor system when stirrups are used. The results of the three tested beams will be presented and discussed in this study. Also the deflection of the beams due to the gradual applied load is monitored and discussed. Cracks will be monitored and recorded during the beam test as the applied load increases.

Keywords: - Swimmer bar, Deflection, Shear, Crack, Stirrup

I. INTRODUCTION

Safety, durability and cost are the main objectives the designers consider in the design of reinforced concrete members. Sudden failure due to shear low strength is not desirable mode of failure. The reinforced concrete beams are designed primarily for flexural strength and shear strength. Beams are structural members used to carry loads primarily by internal moments and shears. In the design of a reinforced concrete member, flexure is usually considered first, leading to the size of the section and the arrangement of reinforcement to provide the necessary resistance for moments. For safety reasons, limits are placed on the amounts of flexural reinforcement to ensure ductile type of failure. Beams are then designed for shear. Since shear failure is frequently sudden with little or no advanced warning, the design for shear must ensure that the shear strength for every member in the structure exceeds the flexural strength. The shear failure mechanism varies depending upon the cross-sectional dimensions, the geometry, the types of loading, and the properties of the member.

Reinforced concrete beams must have an adequate safety margin against bending and shear forces, so that it will perform effectively during its service life. At the ultimate limit state, the combined effects of bending and shear may exceed the resistance capacity of the beam causing tensile cracks. The shear failure is difficult to predict accurately despite extensive experimental research. Retrofitting of reinforced concrete beams with multiple shear cracks is not considered an option (Al-Nasra and Wang, 1994)

Beams subjected to considerable shear forces exhibit diagonal cracks near the beam support, where the shear forces are usually critical. Excessive applied shear forces allows the crack to propagate at a faster rate compared with the bending cracks. Also the width of the diagonal cracks is usually higher than the bending cracks. Shear reinforcements are provided to carry some of the shear forces and prevent the formation of the diagonal cracks. Usually in the civil engineering practice, steel stirrups are used for this purpose. The steel stirrups are placed vertically and upright. The spacing of these stirrups is used as the parameter of design for the applied shear forces.

Bent up bars may also be used to carry some of the shear forces. Commonly, these bent up bars are the positive longitudinal steel reinforcement bent near the support to join the negative steel. Due to construction cost and other technical considerations engineers preferred not to use bent up bars

In this study, three reinforced concrete beams were tested using the new shear reinforcement swimmer bar system and the traditional stirrups system. Several shapes of swimmer bars are used to study the effect of swimmer bar configuration on the shear load carrying capacity of the beams (Al-Nasra et al 2013). Only three beams will be presented in this study. The first beam, BC, is used as a reference control beam where stirrups are used as shear reinforcement. The other two beams were reinforced by swimmer bars. Beam, WSB is the beam which is reinforced by two swimmer bars welded to the longitudinal top and bottom bars. Beam, SSB is the beam which is reinforced by swimmer bars spliced with the longitudinal steel reinforcement. Extra stirrups were used to make sure that the prepared beams will fail by shear in the swimmer bars side. In this investigation, all of the beams are supposed to fail solely in shear, so adequate amount of tension reinforcement were provided to give sufficient bending moment strength. This study aims at investigating a new approach of design of shear reinforcement through the use of splicing swimmer bars provided in the high shear region. The main advantages of this type of shear reinforcement system are: flexibility, simplicity, efficiency, and speed of construction.

AlNasra and Asha (2013) studied the use of swimmer bars welded to the longitudinal steel reinforcement, and concluded that the beam reinforced with welded swimmers bars exhibit better shear resistance compared with the control sample beam reinforced with regular stirrups.

Piyamahant (2002) showed that the existing reinforced concrete structures should have stirrup reinforcement equal to the minimum requirement specified the code. The theoretical analysis shows that the amount of stirrup of 0.2% is appropriate. The paper concluded that small amount of web reinforcement is sufficient to improve the shear carrying capacity. The study focused on the applicability of the superposition method that used in predicting shear carrying capacity of reinforced concrete beam with a small amount of web reinforcement at the shear span ratio of 3. Also the failure mechanisms were considered when small amount of stirrup used.

Sneed, and Julio (2008) discussed the results of experimental research performed to test the hypothesis that the effective depth does not influence the shear strength of reinforced concrete flexural members that do not contain web reinforcement. The results of eight simply supported reinforced concrete beam tests without shear and skin reinforcement were investigated. The beams were designed such that the effective depth is the variable while the values of other traditionally-considered parameters proven to influence the shear strength (such as the compressive strength of concrete, longitudinal reinforcement ratio, shear span-to-depth ratio, and maximum aggregate size) were held constant. The values selected for the parameters held constant were chosen in an attempt to minimize the concrete shear strength.

Noor (2005) presented several results of experimental investigation on six reinforced concrete beams in which their structural behavior in shear was studied. The research conducted was about the use of additional horizontal and independent bent- up bars to increase the beam resistance against shear forces. The main objectives of that study were studying the effectiveness of adding horizontal bars on shear strength in rectangular beams, the effectiveness of shear reinforcement, and determining the optimum amount of both types of shear reinforcement to achieve a shear capacity similar to that of a normal links system. From experimental investigation of the system it was found that, the use of independent horizontal and bent-up bars as shear reinforcement were stronger than conventional shear reinforcement system.

II. SWIMMER BARS

A swimmer bar is a small inclined bar, with its both ends bent horizontally for a short distance, welded, bolted or spliced at the top and the bottom with the longitudinal steel reinforcing bars. There are three major standard shapes; single swimmers, rectangular shape, and rectangular shape with cross bracings. Several additions to these standard shapes can be explored, such as addition of horizontal stiffener bars in the rectangular shapes, dividing the large rectangle horizontally into smaller rectangles. Additional swimmer bars can also be used. By adding one more swimmer bars to the rectangular shape, the large rectangular shape will be divided vertically into two rectangles. The addition of two more swimmer bars at the same section will divide the large rectangle vertically into four small rectangles. A combination of horizontal bars and additional swimmer bars may also be explored. This swimmer bar system is integrated fully with the longitudinal steel bars. Several options of the swimmer bar systems are used in order to improve the shear performance of the reinforced concrete beams, reduce the amount of cracks, reduce the width and the length of cracks and reduce overall beam deflection. Different bar diameters can be used in order to add stiffness to the steel cage, and increase shear strength of the reinforced concrete beam.

III. ACI CODE PROVISION FOR SHEAR DESIGN

According to the ACI Code (ACI 2011), the design of beams for shear is to be based on the following relation:

$$V_u \leq \phi V_n \quad (1)$$

Where: V_u is the total shear force applied at a given section of the beam due to factored loads and $V_n = V_c + V_s$ is the nominal shear strength, equal to the sum of the contribution of the concrete and the web steel if present. Thus for vertical stirrups

$$V_u \leq \phi V_n + (\phi A_v f_{yt} d) / S \quad (2)$$

and for inclined bars

$$V_u \leq \phi V_n + (\phi A_v f_{yt} d (\sin \alpha + \cos \alpha)) / S \quad (3)$$

Where: A_v is the area of one stirrup, α is the angle of the stirrup with the horizontal, S is the stirrup spacing, and f_{yt} is the yield strength.

The nominal shear strength contribution of the concrete (including the contributions from aggregate interlock, dowel action of the main reinforcing bars, and that of the un-cracked concrete) can be simplified as shown in Equation (4).

$$V_c = 0.17 \lambda \sqrt{f_c'} (b_w d) \quad (4)$$

Where: b_w and d are the section dimensions, and for normal weight concrete, $\lambda = 1.0$. This simplified formula is permitted by the ACI code expressed in metric units (Nawy, 2009).

IV. TESTED BEAMS

This study focused on investigating the shear strength of three different types of reinforced concrete beams; beam reinforced with regular stirrups, beam reinforced with welded swimmer bars, beam reinforced with spliced swimmer bars. All specimens were of the same size and reinforced with identical amount of longitudinal steel. The amount of longitudinal steel used in this study is, by design, selected to make sure that the failure will be dictated only by shear and not by bending. The beams were tested to fail due to two point loads by shear given the ratio of a shear span to effective depth of 2.5. The compressive strength of concrete is measured according to ASTM C 192-57. Nine concrete samples were prepared. The compressive strength of concrete is measured at the 28th day. The concrete compressive strength results range between 26.4 N/mm² to 28.8 N/mm². The variables in these specimens are the shear reinforcement systems.

Three reinforced concrete beams were prepared for the test, BS which the beam with regular stirrups, WSB which is the beam with welded swimmer bars, and SSB beam which is the beam reinforced with spliced swimmer bars. All of the beams are of the same dimension 2000 mm length, 200 mm width and 250 mm depth. The effective length was also kept at constant value of 1800 mm, which is the distance between the supports. Summary of shear reinforcement system for each specimen is given in Table 1. All tested beams were designed with 3 ϕ 14 top steel and 4 ϕ 16 bottom steel reinforcement. The reference beam, BC, was designed with 10 ϕ 8 mm at 600 mm spacing vertical stirrup at either side. New type of shear reinforcement called welded swimmer bars 'WSB', and spliced swimmer bars 'SSB' were used in this experiment. The swimmer bars were used as independent bent-up bars and welded/spliced with the longitudinal steel reinforcement. The swimmer bars used in beams WSB and SSB are of ϕ 10 mm and spaced of 275 mm apart as shown in Figure 1. The weight of each steel cage is also listed in Table 1. The weight of each steel cage is almost the same.

Figure (2) shows the steel cage used in beam SSB, the spliced swimmer bars, and Figure 3 shows two spliced swimmer bars forming plane shear interceptor. The weights of the steel cages were intentionally designed to be very close in numbers. The erection and assembling time of the spliced swimmer bars beam is relatively less than the erection and assembling time of the welded beam.

Table 1: Summary of steel reinforcement used in the tested beams

Beam No.	Shear Reinforcement		Steel Cage Weight (N)
	Vertical stirrup	Bent-up Bars	
BC	10 ϕ 8 mm spaced @ 60 mm at shear sides	-	255
WSB	-	Three welded swimmers, ϕ 10 mm spaced @ 275 mm	250
SSB	-	Three spliced swimmers, ϕ 10 mm spaced @ 275 mm	259

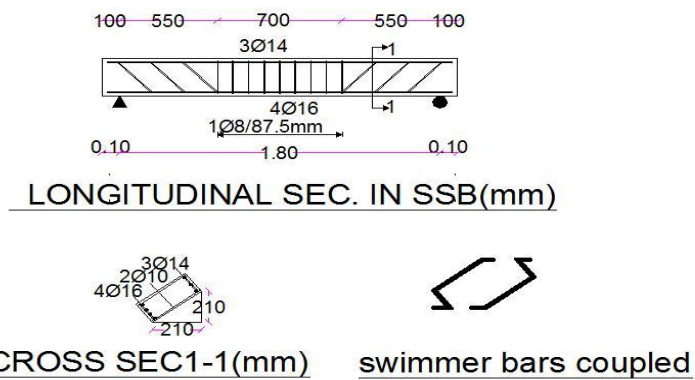

Figure 1: Reinforcement details of the spliced swimmer bars beam, SSB



Figure 2: Steel cage reinforcement of the beam reinforced with spliced swimmer bars, SSB.



Figure 3: Two spliced and coupled swimmer bars.

V. TEST PROCEDURE

Prior to testing, the surface of the specimens was painted with white emulsion for the purpose of making the cracks more visible and easy to track. At the age 28 days, the reinforced concrete beams were prepared for testing. Marking lines were used to show the location of the point loads, supports and the mid-span of the beam in order to make it easier to install the beams on the testing machine. The test was carried out with the specimen placed horizontally in a simple loading arrangement. The beams were supported by solid round steel on their two edges that can be considered as simply supported beam members. All the beams were designed to ensure the beams will only fail in shear rather than in flexure.

To ensure that shear cracks will occur near the support, two point loads were applied symmetrically to the beam with a_v less than $2.5d$. In this testing, $a_v \approx 550$ mm, where a_v is shear span (the distance from the point of the applied load to the support), and d is the effective depth of a beam.

A loading jack was placed at the mid-span position above the beam. The load was applied by jacking the beam against the rig base member at a constant rate until the ultimate load capacity of the beam was reached. A universal column section was used to transfer the load to the beam at two point loads via transfer girder. A reasonable time interval was allowed in between each 20.0 kN load increments for measuring deflections, marking cracks, measuring the shear reinforcement strain and recording the ultimate load. Each beam took about two hours to complete the test. The cracks were monitored at each load increment. Figure 4 shows the experimental set up.



Figure 4: Experimental set up and crack monitoring

VI. TEST RESULTS

The beam BC showed typical mode of failure by shear at the ultimate load of 180 kN. Beam WSB and SSB showed quite similar mode of failure. Several micro-cracks appeared early in the loading process. These cracks were extended and widened as the load increases. These cracks became visible at the load of about 100 kN. As the loading was increased more cracks developed. The cracks migrate towards the top corners as the load increases. More flexure cracks appeared at a load of 100 KN in the bending moment region. These cracks increased by increasing the applied load, and new cracks developed but at relatively slower paste. Figure 5 shows the beam SSB at failure stage which is somewhat similar to the mode of failure of the beams BC, and WSB. The shear crack area stretched from the support to a distance equals about twice the depth. The angle of the first shear crack is about 25 degrees, and propagated fast from the support toward the first applied load. This crack becomes visible at the load of 120 KN. The width and the length of this crack increases with the increase of the applied load. More cracks developed at various distances from the support. The angle of these cracks increases as the crack approaches the applied load. Some measured angles of these cracks are 40, 60 and 73 degrees. It is interesting to mention here that the bending cracks started to become visible at earlier stages of loading compared with the shear cracks. One of the main bending cracks became visible at the load level of 80 KN, and propagated slowly toward the top of the beam. This crack is located at the bottom side of the beam in the med-span area of the beam. In general, it was noticed that the width of the bending cracks is much smaller than the width of the shear cracks. Also, one can notice that the rate of crack propagation of bending cracks is much slower than the rate of propagation of the shear cracks. In general, the shear cracks moved from the support toward the mid-span propagating upward with increasing angle, while the bending cracks remained at the mid-span area and propagated vertically upward toward the top of the beam.



Figure 5: Beam SSB at failure stage.

Figure 7 shows the maximum applied load the beam carried just before failure. All of the tested beams in this study failed by shear. The beam of welded swimmer bars exhibit similar strength as the beam of spliced swimmer bars. This proves that welding can be avoided when dealing with swimmer bars. The welding process is of a major concern when it comes to the quality control of the welds. Splicing swimmer bars provided a practical solution to the welding problem, without jeopardizing the quality or strength.

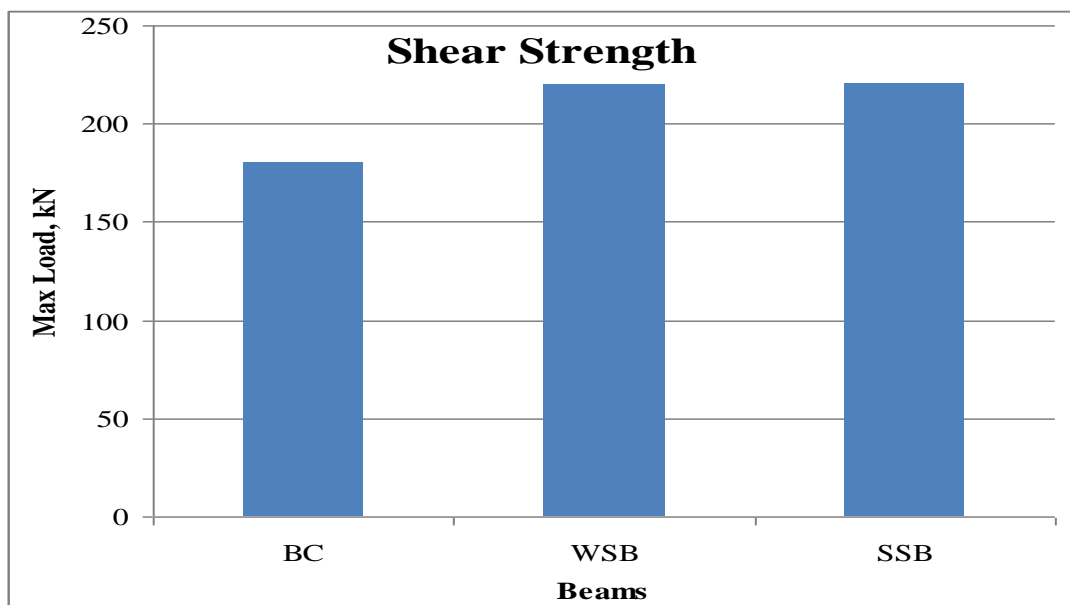

Figure 7: Shear strength of the three tested beams

Figure 8 shows the measured deflection as the applied load increases. No major difference in the load deflection relationship was observed in the tested beams. Beams deflection increased with the increase in applied load up to the failure load. One can notice from Fig. 8 that the behavior of the beam reinforced with welded swimmer bars is very similar to the behavior of the beam reinforced with spliced swimmer bars.

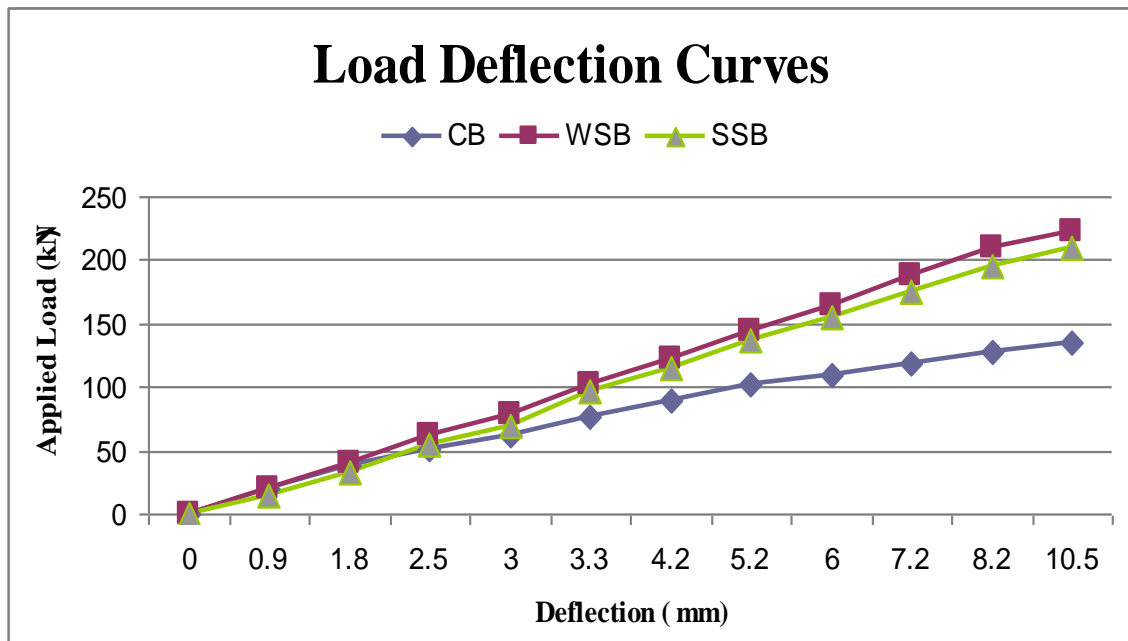

Figure 8: Deflection measured at mid-span as the applied load increases.

VII. CONCLUSIONS

This study presented three different types of shear reinforcement that can be used in reinforced concrete beams. New type of shear reinforcement system was used, which is the splicing swimmer bars system. New shape of swimmer bars is used and spliced with the longitudinal steel reinforcement bars forming plane-shear interceptors. In general there is improvement in shear strength of beams reinforced with swimmer bars over the beams reinforced with the traditional stirrups. The beam reinforced with spliced swimmers bars showed similar results as the beam reinforced with welded swimmer bars. The width and length of the cracks were observed to be less using swimmer bars compared to the traditional stirrups system.

REFERENCES

- [1] Al-Nasra, M.M., and Wang, L.R.L., 1994, Parametric Study of Slab-On-Grade Problems: Due to Initial Warping and Point Loads. *ACI Structural Journal*, Vol. 91 No. 2. <http://www.concrete.org/PUBS/JOURNALS/OLJDetails.asp?Home=SJ&ID=4596>
- [2] Moayyad Al-Nasra, Naeim Asha, "The Use of Bolted U—Link Swimmer Bars in the Reinforced Concrete Beams," *International Organization of Scientific Research, Journal of Engineering (IOSRJEN)*, Vol. 3, Issue 10, Version 5, ISSN Print: 2278-8719, ISSN Online: 2250-3021, DOI: 10.9790/3021-031052632, ANED: 0.4/3021- 031052632, <http://www.iosrjen.org>, Pages 26-32, October, 2013
- [3] Piyamahant, (2002), *Shear behavior of reinforced concrete beams with small amount of web reinforcement*, M. Eng. Dissertation, Kochi University of Technology, Japan
- [4] Lesley H. Sneed and Julio A. 2008, Effect of Depth on the Shear Strength of Concrete Beams without Shear Reinforcement, *USA Portland and cement Association*. <http://www.cement.org/exec2/11-03-08.htm>
- [5] Noor Hamid (2005). *The Use of Horizontal and Inclined Bars as Shear Reinforcement*, Master Thesis, University of Technology, Malaysia, <http://sunzi.lib.hku.hk/hkuto/record/B26643352>.
- [6] ACI 318-11, 2011. *Building Code Requirements for Structural Concrete Commentary*. <http://www.concrete.org/pubs/newpubs/31811.htm>
- [7] Edward G.Nawy, 2009. *Reinforced Concrete: A Fundamental Approach*, Prentice Hall International, US, PP 120-315, ISBN 0132417030, 9780132417037